



...is all you need



SX 854

SX 804

SX 1054

SX 1004

SX 1254

SX 1204

SX STREET PERFORMANCE SUBWOOFER

CONGRATULATIONS !

You now own an EXCURSION SX High Performance Subwoofer, the product of an uncompromising design and german engineering philosophy. A product made from Car Audio fanatics who truly believe in the relentless pursuit of perfection.

EXCURSION Subwoofer are the result of several decades of product improvements, competition, innovation and highest quality parts and control standards in industry. When properly installed these speakers will provide you with many years of listening pleasure and are the perfect balance between high fidelity, extreme performance and long-lasting reliability.

Should your SX Subwoofer ever need a service, Please record your information on the following lines to refer to in the event that you may need it later.

Dealer's Name _____

Date of Purchase _____

Installation Shop _____

Installation Date _____

At EXCURSION Intl. we are confident you will have many years of outstanding enjoyment from your high performance investment. For maximum performance we recommend that you have your new EXCURSION SX Subwoofer installed by an exclusive Authorized EXCURSION Dealer

To learn more about EXCURSION, please visit us on the World Wide Web at

<http://www.excursion.us>

CAUTION !

Continuous exposure to sound pressure levels in excess of 100dB can cause permanent hearing loss. EXCURSION Speakers are capable of producing sound pressure levels well over 170dB. Please observe all local sound ordinances while listening to your EXCURSION System. EXCURSION Intl. accepts no liability for hearing loss, bodily injury, or property damage due to the result of use or misuse of this product.

EXCURSION SX SUBWOOFER FEATURE

Dual Black Mica Poly Cone : The cone and its choice of material effect almost everything in regard to the Sound Quality of the subwoofer. While the cone must remain exceptionally stable under the stress of high sound pressure levels a well balanced formula of maximum stiffness at minimum weight is the prior target next to a high grade internal damping for reproduction from the deepest bottom signals. We at EXCURSION especially took care at this keypoint of a subwoofer and designed an air chamber sandwich technology with a Mica Poly Cone and a full size inversed Mica Poly Dustcap. This sandwich structure keeps a fully closed air chamber between Cone and Dustcap, while it replaces the regular dustcap with a stylish printing. The technology effects together with the Mica Poly material into outstanding damping, which effect into a remarkable bottom FQ performance from smallest enclosures. Built forever SX Subwoofers set the benchmark for closed enclosure applications, but also perform with unbelievable output in handy ported or bandpass enclosures.

Rigid tooled oversized Steel Basket: Their symmetrical design together with the stamped EXCURSION logos ensure outstanding static, aerodynamic and stiffness of our EXCURSION steel baskets. For EXCURSION SX baskets we tricked again with our historical Double Wide Surround (DWS) Technology and our patented Basket Flange Design, produce more cone area than average which support their outputs. All together ensure linear excursion in an extremely rigid non-resonant frame, which fix motor structure and all moving parts together. Coated with black antivibration colour the baskets are acoustical deaden to provide best results. We at EXCURSION took especially care of maximum cooling of voice coil. All baskets are symmetrical vented below the spider for maximum heat transfer, knowing that a cool voice coil is able to take more power and handle more power.

Voice Coils: The heart of EXCURSION SX Subs are these 1.5" carefully designed Voice Coils. Something we may call „Entry“ follow the spirits of a Formula One car. We have choosen our well known finest Kapton formers. Almost weightless, but high grade temperature resitant. We are using the finest pure copper for those high efficient coils and ensure long life of your investment without heart attack.

80 once Motor Structure: The motor structure of a Subwoofer drives the cone. Just like an engine of a car our engines allow your SX Subwoofer transfer a very lot of Power while our even oversized linear spider ensure precise linear movements. Our extra bumped and aero pole vented backplates take care of no limits for the coil. Our EXCURSION rubber boot and gasket will protect the SX Sub and car while installation.

Pre-Installation Instructions:

It is recommended that you have your new EXCURSION SX Subs professionally installed by your authorized EXCURSION dealer. This will ensure use of proper installation techniques & materials. If you choose to perform your own installation, the following instruction will give you direction making your purchase complete.

The factors for the port area are manifold and can not be reduced only to depend on the cone area of the woofer that is used. But at least it is a good advice not to go with less than $1/7$ of the cone area for ported and $1/4$ for bandpass enclosures.

While you are building up and tuning your sub system you should use a trial-port. This should be longer than calculated or recommend. While tuning the system you can find the best sounding length by shortening the port in approx 2 cm steps. The final tuning in the car does not only result out of what you do with the port. Also the position of the port in the enclosure and surrounding areas and position in the trunk have notable impact. The load-through of rear seats are also uncalculable as well size and construction type of the car. This easy effect with different results.

Please do NOT use carpet or cloth within the port or inside the enclosure. It has bad effects on the air flow. It is recommended to round up the ends of the port and ensure a glossy surface where ever the air moves inside the enclosure or port. The moving air mass will speed up and thank you by producing less side noises.

You can also prevent the port itself from resonating. The techniques are the same as you know from building enclosures or damping doors. You can use energy absorbing material or you can raise the stiffness of the port by bracing.

To have your subwoofer system playing clear and accurate you must follow the idea of an acoustical "dead" workplace, with just the moving cone. First of all, the enclosure itself might be not rigid enough. In most cases you can raise the stiffness by implementing braces, that connect in best way four walls. Or at least stiff up the baffle against back-wall. You can build enclosures with wallthickness of many centimetres, but bracing will have same effect with less weight! Now, when your enclosure is stiff and rigid to save you against bomb attacks, you can put it in your trunk. Do not forget it is important to fix it in the trunk of your car.

For further direction consult an authorized EXCURSION installation specialist

If you are intending to use multiple subwoofers in your system, EXCURSION recommends having separate chambers for each subwoofer if the subwoofers will be operated by different amplified signals. This prevents possible cancellation.

WARNING: The use of silicone rubber to seal in a speaker will void the Warranty! If sealing is needed to the speaker gasket, use caulking cord or vinyl weather strip.

IMPORTANT: Never cut any metal that is an integral part of an automobile's safety or structural support system.

NOTE: EXCURSION strongly recommends that you operate the complete audio system at low volume before final installation of your SHX Series Subwoofers. This will allow a trial listening test to set maximum volume without distortion.

CAUTION: Make sure that all speaker wiring is fully protected from cutting or wear. Any short circuits developing as a result could severely damage the radio unit or amplifier. Make sure that all speaker wires easily reach the speaker terminals without stress on the wire or connectors.

PREPARING FOR INSTALLATION

Note: The tools listed below may be required for proper installation.

- * An electric drill with drill bits
- * Phillips-head and standard screwdrivers
- * Crimping tool and needle-nose pliers
- * Silicon sealant or closed cell weather-stripping
- * Metal file, Hole saw, Tin Snips, Wire strippers

INSTALLATION PRECAUTIONS

Note: Proceed only if you are a qualified installer otherwise let your dealer do it.

- * Always wear protective eyewear when using tools
- * Turn OFF all stereo and other electrical devices before you begin
- * Disconnect the (-) negative lead from your vehicle's battery.
- * Keep the speakers in the package until final installation.
- * Locate fuel lines, brake lines, oil lines, electrical cables when planning installation.
- * Check to see clearance behind the mounting surface before installing speakers.
- * When running speaker wires through sheet metal, be sure to use grommets to properly insulate the wires from metal edges.

8" TSP DATAS & ENCLOSURE RECOMMENDATION**SX-8S4**

VC: 4 ohm
 Test: 3,6 ohms
 Fs: 29 Hz
 Vas: 25 Liter
 Qms: 5,16
 Qes: 0,392
 Qts: 0,364
 Mms: 82,3
 BLTM: 11,8
 SD: 226,9 sqCM
 Cms: 0,349 mm/N
 Le: 3,7 mH
 No: 0,15%
 Splo: 84,2 dB
 Xmax: 7 / 13 mm

Closed 8" SQPL Box :

Internal Volume: 7 Liter
 F3: 63,5 Hz
 QTC: 0,8

Ported 8" SPL Box :

Internal Volume: 30,3 Liter
 VB nett Volume: 27,6 Liter
 Port Diameter: 1x 100 mm
 Port Length: each 250 mm
 F3: 41,9 Hz
 FB: 53,3 Hz

SX-8D4

VC: 2x 4 ohm
 Test: 6,1 ohms
 Fs: 29,8 Hz
 Vas: 25,8 Liter
 Qms: 5,468
 Qes: 0,367
 Qts: 0,344
 Mms: 80,7 g
 BLTM: 15,9
 SD: 226,9 sqCM
 Cms: 0,354 mm/N
 Le: 7,9 mH
 No: 0,18 %
 Splo: 84,2 dB
 Xmax: 7 / 13 mm

Closed 8" SQ Box :

Internal Volume: 10 Liter
 F3: 59,7 Hz
 QTC: 0,7

Ported 8" SQPL Box :

Internal Volume: 16,0 Liter
 VB nett Volume: 20,8 Liter
 Port Height: 25 mm
 Port Wide: 238 mm
 Port Length: 359 mm
 F3: 44,1 Hz - FB: 54,3 Hz

10" TSP DATAS & ENCLOSURE RECOMMENDATION

SX-10S4

VC: 4 ohm
Test: 3,6 ohms
Fs: 33 Hz
Vas: 41 Liter
Qms: 3,628
Qes: 0,61
Qts: 0,522
Mms: 111 g
BL™: 11,7
SD: 369,5 sqCM
Cms: 0,205 mm/N
Le: 3,8 mH
No: 0,23%
Splo: 86 dB
Xmax: 7 / 13 mm

Closed 10" SQPL Box :

Internal Volume: 15 Liter
F3: 55,3 Hz
QTC: 0,9

Ported 10" SPL Box :

Internal Volume: 42,8 Liter
VB nett Volume: 38,8 Liter
Port Diameter: 2x 75 mm
Port Length: each 240 mm
F3: 41,5 Hz
FB: 49,4 Hz

SX-10D4

VC: 2x 4 ohm
Test: 6,4 ohms
Fs: 28,4 Hz
Vas: 50 Liter
Qms: 5,336
Qes: 0,523
Qts: 0,477
Mms: 122 g
BL™: 16,3
SD: 369,5 sqCM
Cms: 0,258 mm/N
Le: 7,9 mH
No: 0,211 %
Splo: 86,1 dB
Xmax: 7 / 13 mm

Closed 10" SQ Box :

Internal Volume: 32 Liter
F3: 49,8 Hz
QTC: 0,7

Ported 10" SQPL Box :

Internal Volume: 40,0 Liter
VB nett Volume: 31,3 Liter
Port Height: 38 mm
Port Wide: 332 mm
Port Length: 390 mm
F3: 44,8 Hz - FB: 53,0 Hz

12" TSP DATAS & ENCLOSURE RECOMMENDATION**SX-12S4**

VC: 4 ohm
 Test: 3,6 ohms
 Fs: 29 Hz
 Vas: 105 Liter
 Qms: 3,604
 Qes: 0,709
 Qts: 0,592
 Mms: 131 g
 BL™: 11,1
 SD: 572,5 sqCM
 Cms: 0,226 mm/N
 Le: 3,6 mH
 No: 0,348 %
 Splo: 86,5 dB
 Xmax: 7 / 13 mm

Closed 12" SQPL Box :

Internal Volume: 48 Liter
 F3: 44,73 Hz
 QTC: 0,9

Ported 12" SPL Box :

Internal Volume: 56,2 Liter
 VB nett Volume: 49,2 Liter
 Port Diameter: 2x 100 mm
 Port Length: each 250 mm
 F3: 46,2 Hz
 FB: 55,0 Hz

SX-12D4

VC: 2x 4 ohm
 Test: 6,4 ohms
 Fs: 29,3 Hz
 Vas: 96,0 Liter
 Qms: 5,798
 Qes: 0,799
 Qts: 0,702
 Mms: 143 g
 BL™: 14,5
 SD: 572,5 sqCM
 Cms: 0,206 mm/N
 Le: 7,9 mH
 No: 0,291 %
 Splo: 86,7 dB
 Xmax: 7 / 13 mm

Closed 12" SQ Box :

Internal Volume: 72 Liter
 F3: 41,76 Hz
 QTC: 0,9

Ported 12" SPL Box :

Internal Volume: 51,0 Liter
 VB nett Volume: 39,0 Liter
 Port Wide: 382 mm
 Port Height: 42 mm
 Port Length: 390 mm
 F3: 46,6 Hz - FB: 53,0 Hz

WIRING DIAGRAM

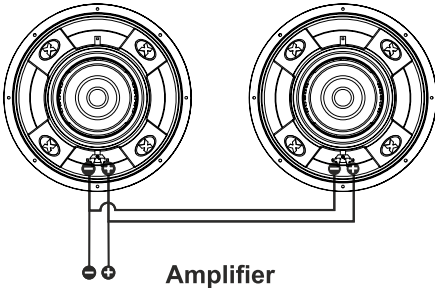

Parallel 2x Single 4 ohm subs = **2 ohm**

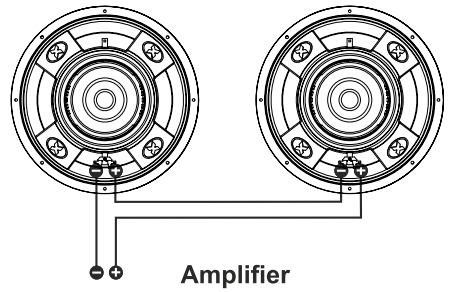

Series 2x Single 4 ohm subs = **8 ohm**

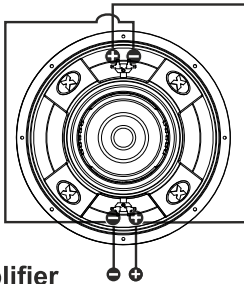

Parallel 1x Dual 4 ohm sub = **2 ohm**

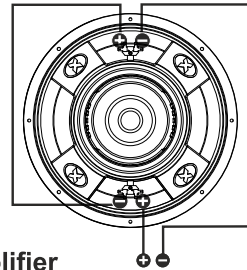

Series 1x Dual 4 ohm sub = **8 ohm**

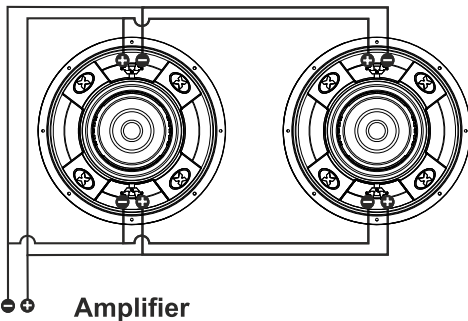

Parallel-Parallel 2x Dual 4 ohm subs = **1 ohm**

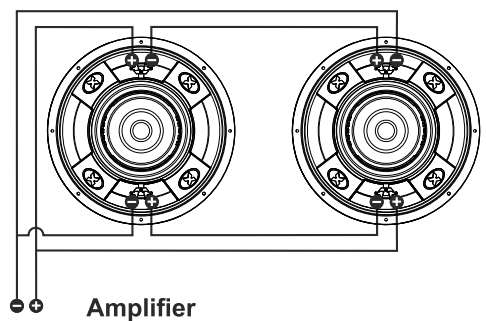

Series-Parallel 2x Dual 4 ohm sub = **4 ohm**

SPECIFICATIONS FOR EXCURSION SX SUBWOOFER SERIES

(Due to Constant Improvements, Specifications and Parameters are subject to change without notice)

Model	Size	Nominal Impedance	Power RMS/PEAK	Sensitivity 1W/1m	Motor Size	Mounting Depth	Inner Dia. Cut out	Outer Dia.	Kg
SX-8S4	8"/20cm	1x4Ohm	200 / 600 W	88dB	80 oz.	108mm	187mm	215mm	2.8
SX-8D4	8"/20cm	2x4Ohm	200 / 600 W	88dB	80 oz.	108mm	187mm	215mm	2.8
SX-10S4	10"/25cm	1x4Ohm	200 / 600 W	89dB	80 oz.	124mm	235mm	276mm	3,2
SX-10D4	10"/25cm	2x4Ohm	200 / 600 W	89dB	80 oz.	124mm	235mm	276mm	3,2
SX-12S4	12"/30cm	1x4Ohm	200 / 600 W	90dB	80 oz.	138mm	283mm	325mm	3,4
SX-12D4	12"/30cm	2x4Ohm	200 / 600 W	90dB	80 oz.	138mm	283mm	325mm	3,4

CAUTION : Excursion Subwoofer are capable of producing dangerous SPL levels

ATTENTION : Excursion Subwoofer demand at least 50 hours break in time for maximum Performance.

EXCURSION LIMITED WARRANTY POLICY

EXCURSION Intl. offers limited warranty on EXCURSION products under normal use on the following terms:

EXCURSION Speakers are to be free of defects in material and workmanship for a period of one year.

This warranty applies only to EXCURSION products sold to consumers by Authorized EXCURSION Dealers in Germany. Products purchased by consumers from an EXCURSION dealer in another country are covered only by that country's Distributor and not by EXCURSION Intl.

This warranty covers only the original purchaser of EXCURSION product. In order to receive service, the purchaser must provide EXCURSION with the receipt stating the consumer name, dealer, product and date of purchase.

Products found to be defective during the warranty period will be repaired or replaced (with a product deemed to be equivalent) at Excursion's discretion and will not be liable for incidental or consequential damages. EXCURSION will not warranty this product under the following situations:

- * **Speakers received with bent frames or water damages**
- * **Abuse such as holes in the cone, surround or ripped spider**
- * **Voice coil damage due to amplifier clipping or distortion**
- * **Product that has not been installed according to this owner manual**

Any implied warranties including warranties of fitness for use and merchantability are limited in duration to the period of the express warranty set forth above. No person is authorized to assume for EXCURSION any other liability in connection with the sale of this product.

Please call prior your authorized EXCURSION dealer the product got purchased. In case they are not accessible call 0961-416-0420 for EXCURSION Customer Service. You must obtain an RA# (Return Authorization Number) to return any product to EXCURSION Intl. The RA number must be prominently marked on the outside of the shipping carton or the delivery will be refused. Please pack your return carefully! We are not responsible for items damaged in shipping. Return the defective product along with a copy of the original dated retail sales receipt, plus 10,- EUR for handling and diagnostic evaluation to:

EXCURSION Intl. - A Division of CHPW
Attn: Returns (RA#)
Neustaedter Str. 20
D-92685 Floss / Germany



...is all you need

EXCURSION - A Division of CHPW

All Rights reserved - Intl. Trademark No: 010 640 597

Friedrich-Ebert-Str. 42 - D-92637 Weiden / Germany
Tel: (+49) 961-416 04 20 - Fax: (+49) 961-46 04 41

